

- o The light source in this luminaire may be replaced only by the manufacturer or its contractual service technician or a similarly qualified person!
- o Die Lichtquelle dieser Leuchte darf nur vom Hersteller oder einem von ihm beauftragten Servicetechniker oder einer vergleichbar qualifizierten Person ersetzt werden.

- o The installation may only be carried by authorised specialist. Always switch-off the power supply before carrying out any maintenance.
- o Die Leuchtenmontage kann nur von autorisiertem Fachpersonal durchgeführt werden. Vor der beliebigen Wartungsausführung die Einspeisung abschalten.

- o The manufacturer is not responsible for the incorrect use and assembly of its products.
- o Der Hersteller trägt keine Verantwortung für eine falsche Verwendung des Produktes.

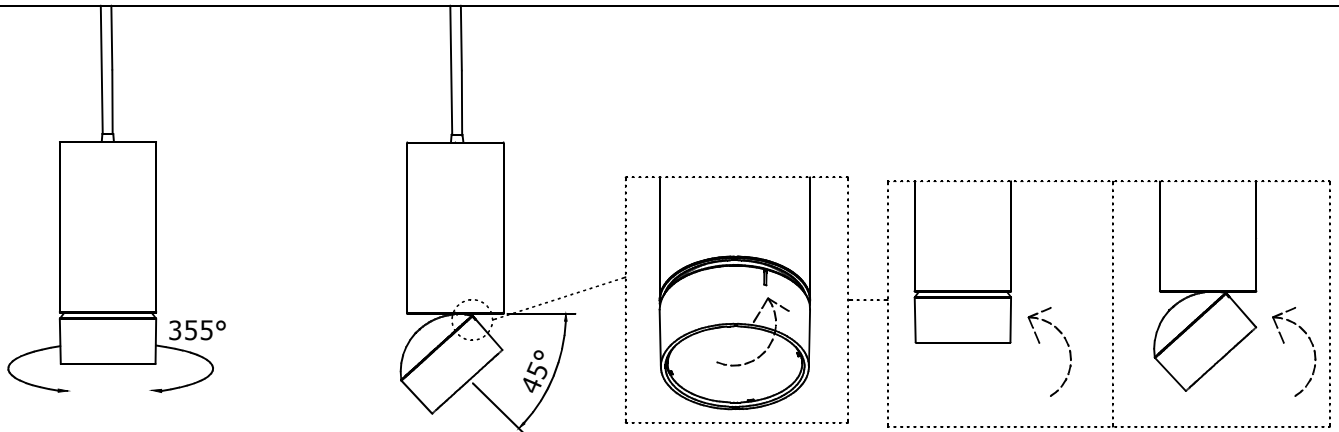
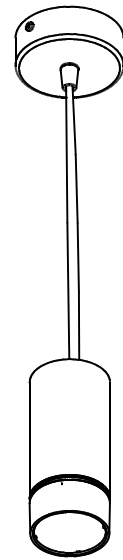
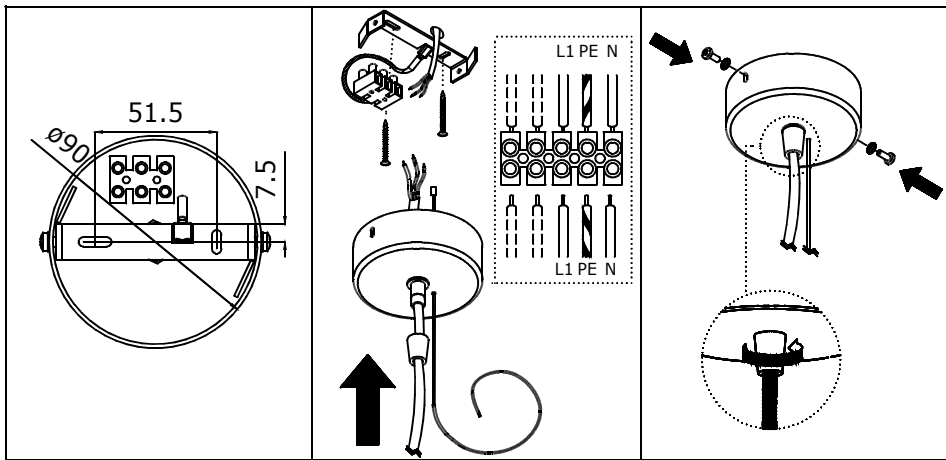
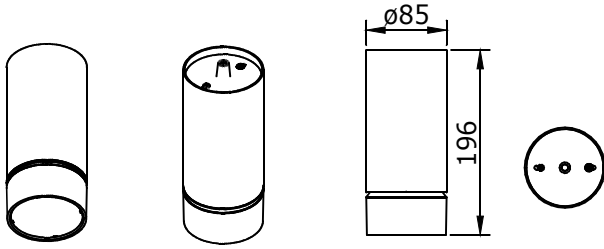
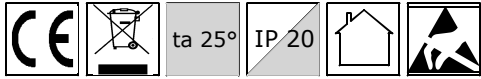

- o The light source in this luminaire may be replaced only by the manufacturer or its contractual service technician or a similarly qualified person!
- o Die Lichtquelle dieser Leuchte darf nur vom Hersteller oder einem von ihm beauftragten Servicetechniker oder einer vergleichbar qualifizierten Person ersetzt werden.

- o The installation may only be carried by authorised specialist. Always switch-off the power supply before carrying out any maintenance.
- o Die Leuchtenmontage kann nur von autorisiertem Fachpersonal durchgeführt werden. Vor der beliebigen Wartungsausführung die Einspeisung abschalten.

- o The manufacturer is not responsible for the incorrect use and assembly of its products.
- o Der Hersteller trägt keine Verantwortung für eine falsche Verwendung des Produktes.

◦ Instructions for wiring
◦ Elektrische Schaltung

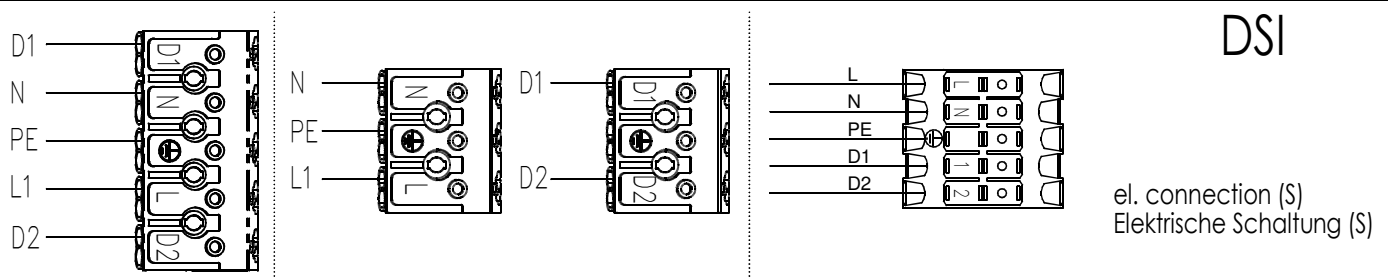
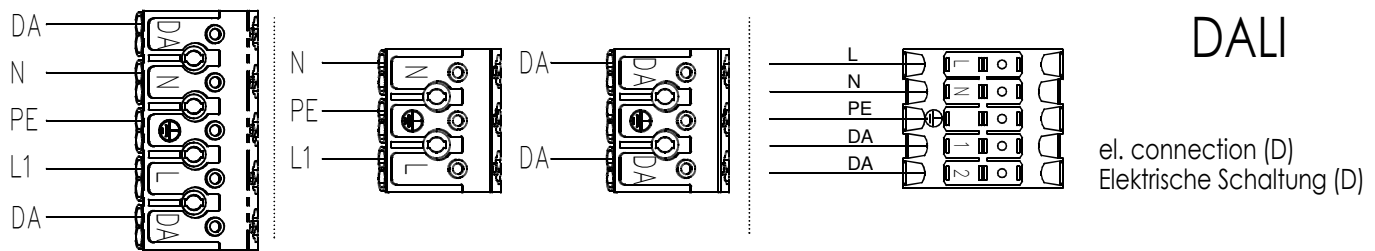
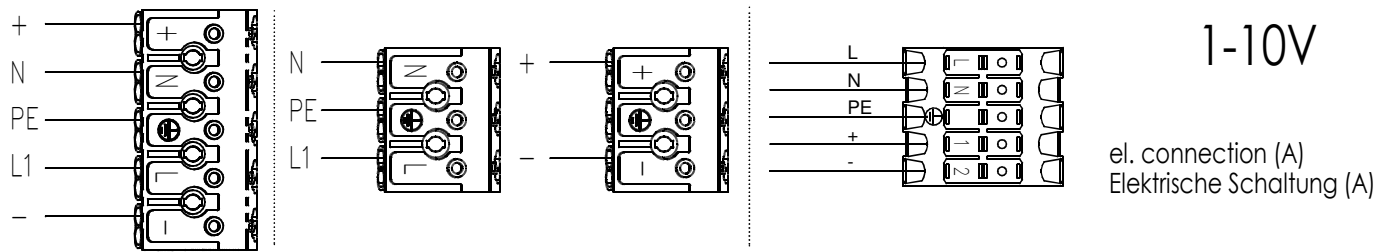
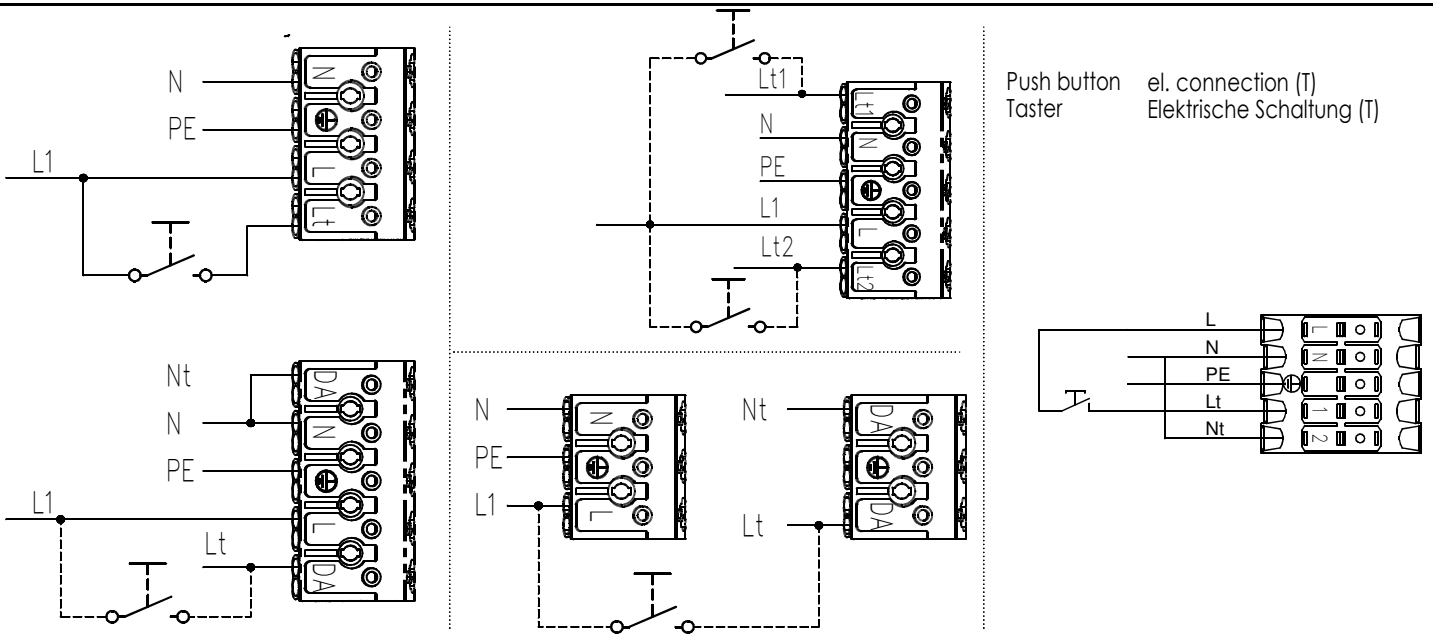

with cable connected mit angeschlossenem Kabel

