

INSTALLATION INSTRUCTIONS
Surface Lighting_299Lighting

**BELLART
MINI
SURFACE**

BELLART MINI SURFACE

INSTALLATION INSTRUCTIONS

1.

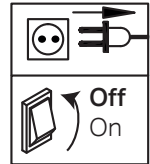
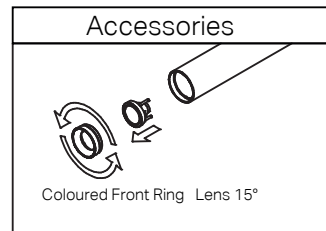
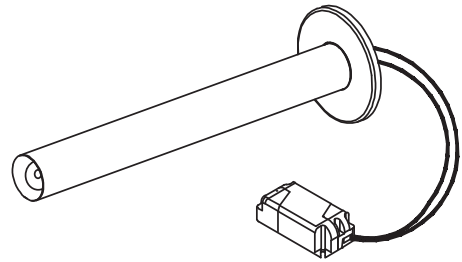
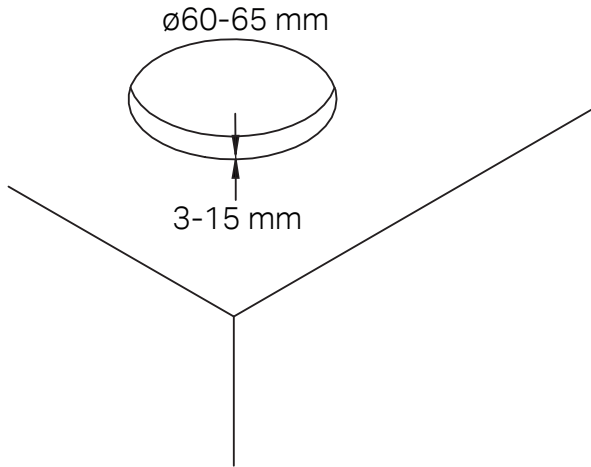

2.

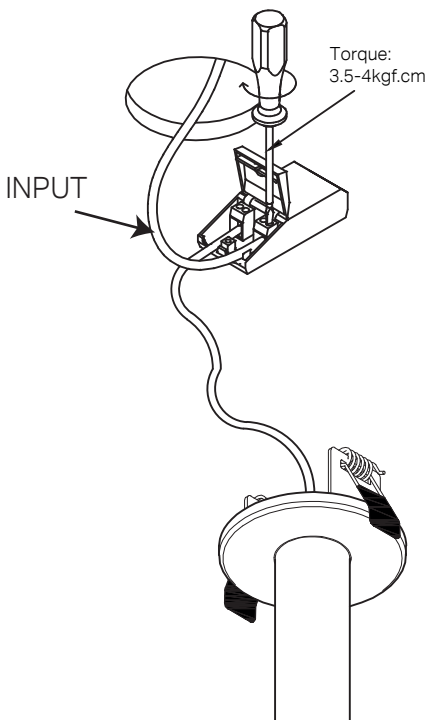

3.

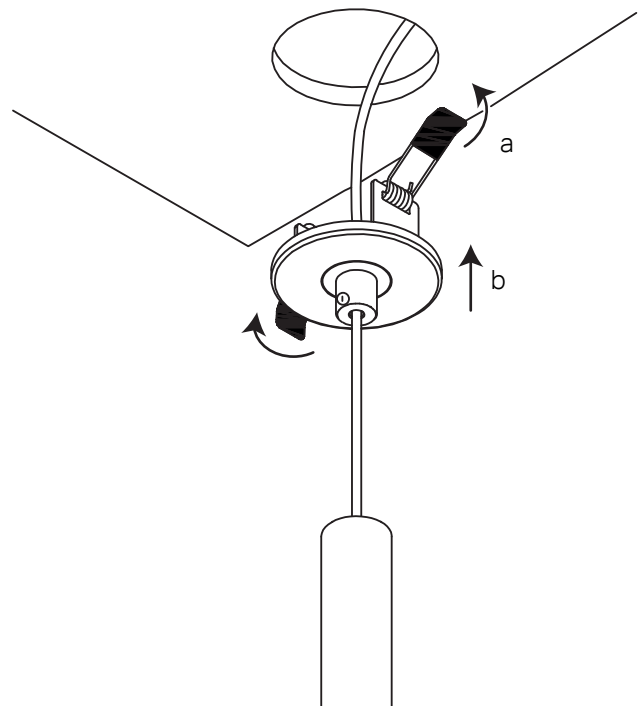

BELLART MINI SURFACE

INSTALLATION INSTRUCTIONS

4.

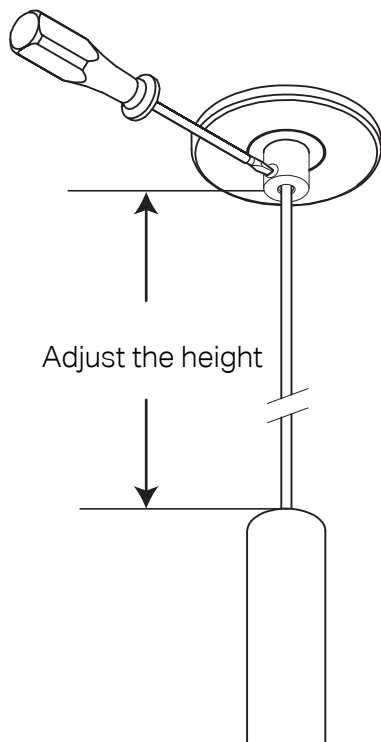

5.

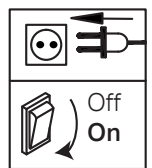
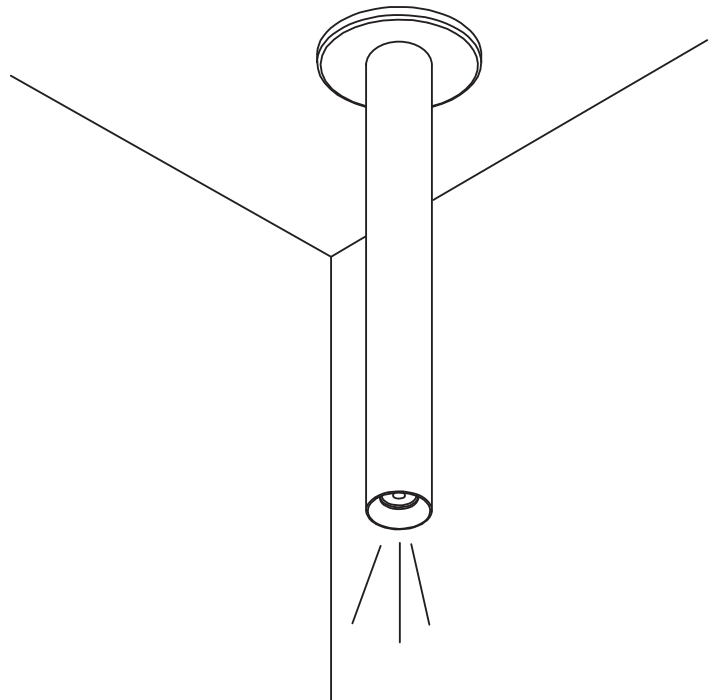

Safety Notes

The safety of this luminaire is guaranteed only if you comply with these instructions; remember to conserve in a safe place
Ensure adequate voltage and frequency is supplied to the equipment
Disconnect from the main power before performing or any maintenance
The installation should be carried out by qualified personnel
For indoor use only

